

NIPPER BATTEN GEN2



PRODUCT DETAILS

- Size: 5ft/1500mm, 4ft/1200mm, 2ft/600mm
- Lumen maintenance: L80 54,000hrs @ +40°C
- LED: Colour Select 4000K/5000K/6500K, CRI80, 5SDCM
- Beam angle: Symmetrical, 120°
- Driver: Integral, Lumen Select, Non dimmable
- Flicker free: PstLM_s≤1, SVM≤0.4
- Rating: IP20, Class I
- Operating temperature: 0°C to +40°C
- Housing: Steel
- Finishing: White RAL9016, Powder coated
- Diffuser/Lens: Polycarbonate (PC), Opal, Insect proof
- Connection: Removable LED module with quick release connector, Ø20mm knockout for conduit or cable glands, Center cable entry, End to end mounting
- Warranty: 5 year

APPLICATIONS

Surface mounted (ceiling/wall), Internal Commercial, Retail, Residential

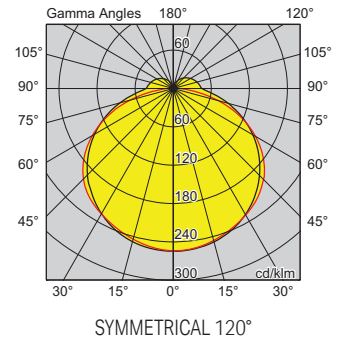
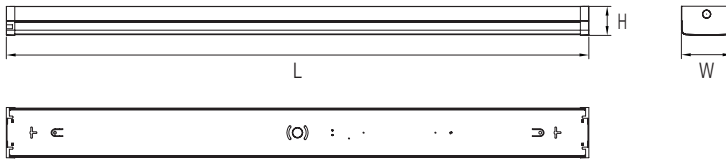

VERSION	A (MM)	B (MM)	C (MM)
NIPBAT505ECSLSG2	1500	130	74
NIPBAT404ECSLSG2	1230	130	74
NIPBAT202ECSLSG2	630	130	74

CODE	DESCRIPTION	POWER	LUMENS	EFFICACY	WEIGHT
NIPBAT505ECSLSG2	NIPPER LED BATTEN 50W 5FT COL SELECT & LUMEN SELECT NON DIM	50W	6300LM	126LM/W	2.6KG
		45W	5700LM	127LM/W	
		35W	4700LM	134LM/W	
		30W	3900LM	130LM/W	
NIPBAT404ECSLSG2	NIPPER LED BATTEN 36W 4FT COL SELECT & LUMEN SELECT NON DIM	36W	4000LM	111LM/W	2.1KG
		30W	3500LM	117LM/W	
		25W	3000LM	120LM/W	
		20W	2400LM	120LM/W	
NIPBAT202ECSLSG2	NIPPER LED BATTEN 18W 2FT COL SELECT & LUMEN SELECT NON DIM	18W	1900LM	106LM/W	1.2KG
		16W	1700LM	106LM/W	
		14W	1500LM	107LM/W	
		11W	1200LM	109LM/W	

"POWER" is tested system powers from luminaire; "LUMENS" is delivered lumens from luminaire, including thermal, electrical and optic losses; ^Figures are interpolated / extrapolated from data at other versions.